

BIG - BAG - UNLOADER

for free flowing bulk materials



Special features :

- ✓ for free flowing bulk materials
- ✓ feed opening Ø 400 mm with removable lid
- ✓ cover removable
- ✓ cone with suction box and suction probe
for the product removal of suction conveyor
- ✓ conveying air intake filter

Option:

- fill nozzle diameter to customer care
- aluminium or stainless steel

Art.No.	Material	Volume	Fill nozzle Pc.	Ø
2407.08	aluminium	250 l	2	70
2408.08	aluminium	400 l	2	70
2409.08	aluminium	750 l	2	70
2410.08	aluminium	1.250 l	2	70
1998.08	stainless steel	250 l	4	40
1298.08	stainless steel	400 l	4	40
1999.08	stainless steel	750 l	4	40
1917.08	stainless steel	1.250 l	4	40

BIG-BAG-BIN

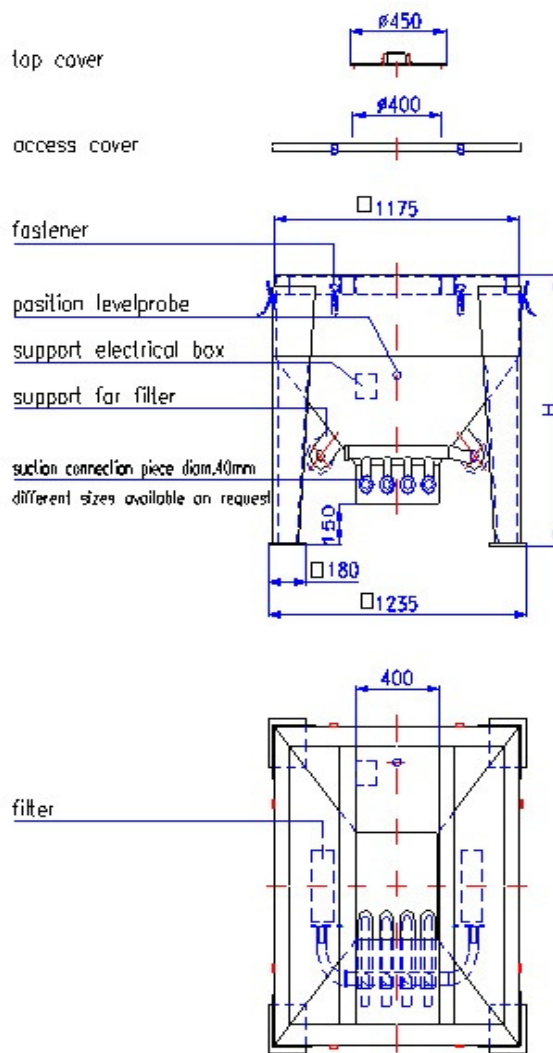

OPTION

BIG-BAG-adapter

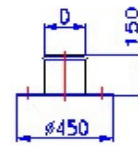

support
BIG-BAG

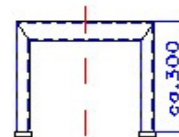

BIG-BAG-BIN	
volume	H (mm)
250 l	800
400 l	1000
750 l	1250
1000 l	1400
1250 l	1600

load capacity-1500kg

BIG-BAG-adapter	
nominal diameter	internal diam. mm
150	140
260	250
300	290
390	380

further OPTIONS:

- inspection glass
- levelindicator
(capozitiv, pnp, 24VDC)
- sieveinsert

Lanco GmbH

Moselstrasse 56-58

D-63452 Hanau

Tel: +49 (0) 6181 91600 - 0

Fax: +49 (0) 6181 91600 - 40

www.lanco.de