

Insulated Hoppers

made of aluminium or stainless steel

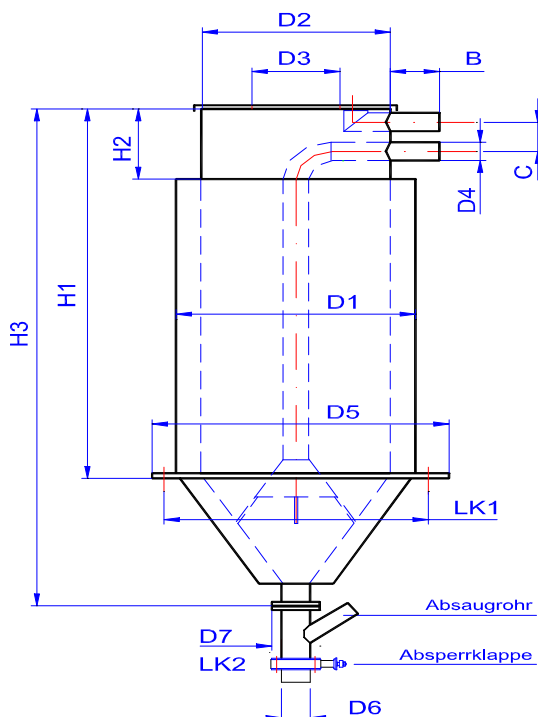

Special Features:

- ✓ hopper insulated with 50 mm thickness ceramic fibre for working temperatures up to 200 °C
- ✓ hopper lid with chamber for Lanco hopper loader
- ✓ cone with adapter flange

Option:

- Inspection door for easier cleaning
- other manufactured size on application

	H1	H2	H3	D1	D2	D3	D4	C	B	D5	LK1	D6	LK2	Art.-No.
50L	500	200	830	500	400	193	50	80	100	580	550	90	130	2089.08
100L	1000	250	1330	500	400	193	60	90	100	580	550	90	130	2091.08
200L	1250	250	1640	570	465	193	60	90	140	640	610	90	130	2093.08
300L	950	300	1490	740	640	193	90	120	150	820	790	90	130	2094.08
400L	1250	300	1790	740	640	193	90	120	150	820	790	90	130	2095.08
600L	1250	380	1925	900	800	268	120	160	150	970	940	90	130	2097.08
800L	1500	380	2180	900	800	268	120	160	150	980	950	90	130	2098.08
1000L	2200	380	2580	900	800	268	150	470	150	1100	1070	150	176	2619.08
1200L	1800	380	2559	999	894	268	150	470	150	1100	1070	150	176	1203.08
1600L	1800	1800	2559	999	894	268	150	470	150	1100	1070	150	176	2562.08
2500L	2340	494	3330	1262	1160	268	150	470	150	1100	1070	150	176	2061.08

Lanco GmbH

Moselstrasse 56-58

D-63452 Hanau

Tel: +49 (0) 6181 91600 - 0

Fax: +49 (0) 6181 91600 - 40

www.lanco.de