

Mixer MT210 / MT290

to continuous mixing of different material components

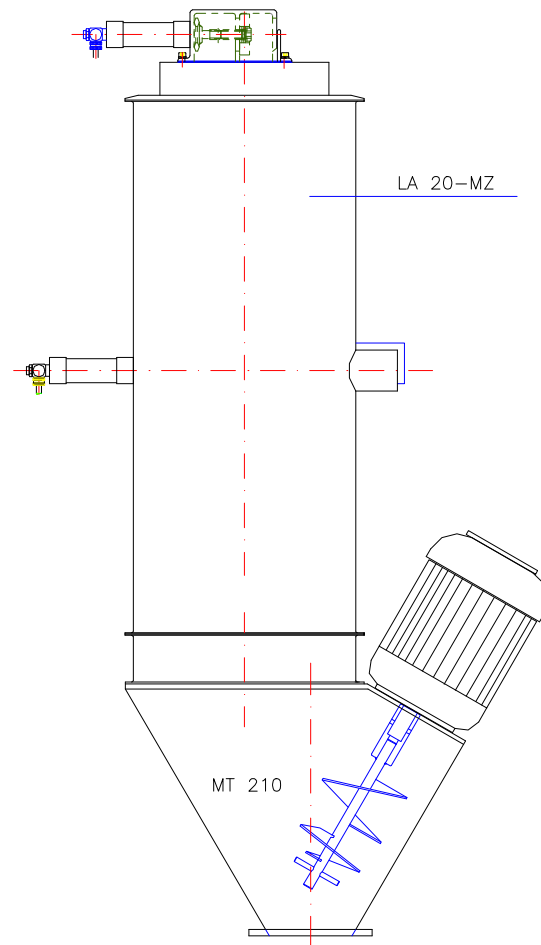

Special features:

- ✓ small compact construction
- ✓ stainless steel hopper
- ✓ prepared to the admission of a hopper loader
- ✓ funnel approx. 6 litres of volume
- ✓ time switch relay in the interval of 1 – 10 minutes adjustable

Lanco GmbH
Moselstrasse 56-58
D-63452 Hanau
Tel: +49 (0) 6181 91600 - 0
Fax: +49 (0) 6181 91600 - 40
www.lanco.de